

Installation and Maintenance Manual

MFW-I

FlatWinder™ 250 - 500



HARKEN®

Glossary	3
Safety Information	4
General advice	5
Introduction.....	6
Technical characteristics	6
<i>Performance data</i>	6
<i>Weight</i>	7
<i>Maximum working load</i>	7
Outline FlatWinder™250	8
Outline FlatWinder™500	11
Installation.....	14
<i>FlatWinder™ installation procedure</i>	15
<i>Electric wiring diagrams</i>	20
<i>Rope installation</i>	22
Maintenance	22
<i>Washing</i>	22
<i>Maintenance table</i>	23
<i>Disassembly procedure</i>	24
Harken® limited worldwide warranty	25
Ordering spare parts	25
Exploded view	26
<i>FlatWinder™ 250</i>	26
<i>FlatWinder™ 500</i>	28
<i>Horizontal electric motor 12V/24V FlatWinder™250</i>	30
<i>Horizontal electric motor 48V FlatWinder™250</i>	32
<i>Horizontal hydraulic motor 8cc FlatWinder™250</i>	34
<i>Horizontal electric motor 12V/24V FlatWinder™500</i>	36
<i>Horizontal electric motor 48V FlatWinder™500</i>	38
<i>Horizontal hydraulic motor 8cc FlatWinder™500</i>	40
Contact us	42

Glossary

Intended use – specific and proper use of the device for which it is designed

Improper use – use of the device in a different way from that indicated in the instructions specified in this manual

Qualified operator – person who has attended specialization and training about the use of the device

User – person who uses the device regularly

Maximum working load (MWL) – maximum value of the load the device can bear



WARNING!

this denotes mandatory actions by the user; without these actions, the user is subjected to injury and the device can be seriously damaged



DANGER!

this denotes the existence of the potential danger, which could cause injury or damage if the information or instructions are not followed



NOTICE! this denotes important information concerning the device

Safety Information



WARNING! Read this manual carefully and fully understood before using the system to avoid personal injury or property damage during system operation.

- Install and use the device only as described in the technical information supplied.
- Improper use can cause severe harms to users, equipment and the boat.
- This information is DESTINED EXCLUSIVELY for qualified operators.
- Installation of the device by personnel who are not experts may cause serious damage to the devices and the boat.
- Never substitute any device part with one that is not original. Even though they look similar and are both made by Harken, the non-original part may not be suitable and the warranty will be invalidated.
- Do not apply to the device loads greater than the MWL (Maximum Working Load).
- Wear suitable clothing when using the device, to avoid loose ends of fabric becoming entangled in the device.
- If the device is powered by an electric motor:
 - Make sure the power is switched off before installing or carrying out maintenance on the device.
- If the device is powered by a hydraulic motor:
 - Do not operate the hydraulic motor during installation or maintenance
 - Do not let the oil in the system comes into contact with your eyes or skin.
- Harken cannot be responsible for damage or injury resulting from unsafe product use, lack of maintenance or incorrect product and /or system installation or operation.
- This manual is an integral part of the device and aims to provide all the information needed for its safe and correct use and for proper maintenance
- This manual gives technical information on device installation and maintenance, including disassembling and reassembling.
- Installation, disassembling and reassembling of the device by personnel who are not experts may cause serious damage to users and those in the proximity of the device.
- This manual is available only in English. If you do not fully understand the English language, do not carry out the operations described in this Manual. For any doubts, questions or comments contact the Harken distributors nearest to you, Special Project assistance, or contact the Harken Italy Technical Service by e-mail: techservice@harken.it
- See www.harken.com for additional safety information.

General advice

Intended use

Harken devices are designed and manufactured for a use on sailing boats to control sheets, halyards and related sail and rig systems. For any other usage, contact the Harken Italy Technical Service by e-mail: techservice@harken.it

Improper use

The Harken device must not be used for purposes different from those outlined in “Intended use” chapter, or for purposes not mentioned in this manual or different from those mentioned.

The Harken device must not be used if unauthorized modifications or interventions have been carried out. Do not use the device for hauling, mooring the boat or weighing the anchor.

Do not take turns round the base of the device drum.

Do not use the device to turn a line to another device (cross-sheeting).

Introduction

This manual gives technical information on FlatWinder™ installation and maintenance, including disassembling and reassembling.

This information is destined exclusively for specialized personnel or expert users. Installation, disassembling and reassembling of the FlatWinder™ by personnel who are not experts may cause serious damage to users and those in the vicinity of the FlatWinder™.

Harken® accepts no responsibility for defective installation or reassembly of its FlatWinder™.

In case of doubt the Harken® Tech Service is at your disposal at techservice@harken.it

This manual is available only in English. If you do not fully understand the English language, do not carry out the operations described in this manual.

Technical characteristics

Rope diameter: Ø10

Performance data

Electric motor

	FlatWinder™ 250			FlatWinder™ 500		
Voltage [V]	12	24	48	12	24	48
Max load [kg]	250	250	250	500	500	500
Line speed [m/min]**	35	42	47	26	28	31
Current absorption at max load [A]	210	140	73	320	160	85

***Line speed is measured with no load*

Hydraulic motor

	FlatWinder™ 250	FlatWinder™ 500
Displacement [cc]	8	8
Max load [kg]	250	500
Line speed [m/min]**	19	12.5
Pressure	80	95

Weight

	FW250			FW500		
	E 12V/24V A	E 48V A	HY A	E 12V/24V A	E 48V A	HY A
weight [kg]	12.5	12.8	8.4	22.5	24.3	17.1

E = Electric motor

HY = Hydraulic motor

A = anodized aluminum base and pulley

Maximum working load



WARNING!

The maximum working load (MWL) for the FlatWinder™250 is 250 Kg (551 lb) and for the FlatWinder™500 is 500 Kg (1102 lb)

Subjecting the FlatWinder™ to loads above the maximum working load can cause the FlatWinder™ to fail or pull off the deck suddenly and unexpectedly during high loads causing severe injury or death.

Outline FlatWinder™250

FW250 E 12V/24V

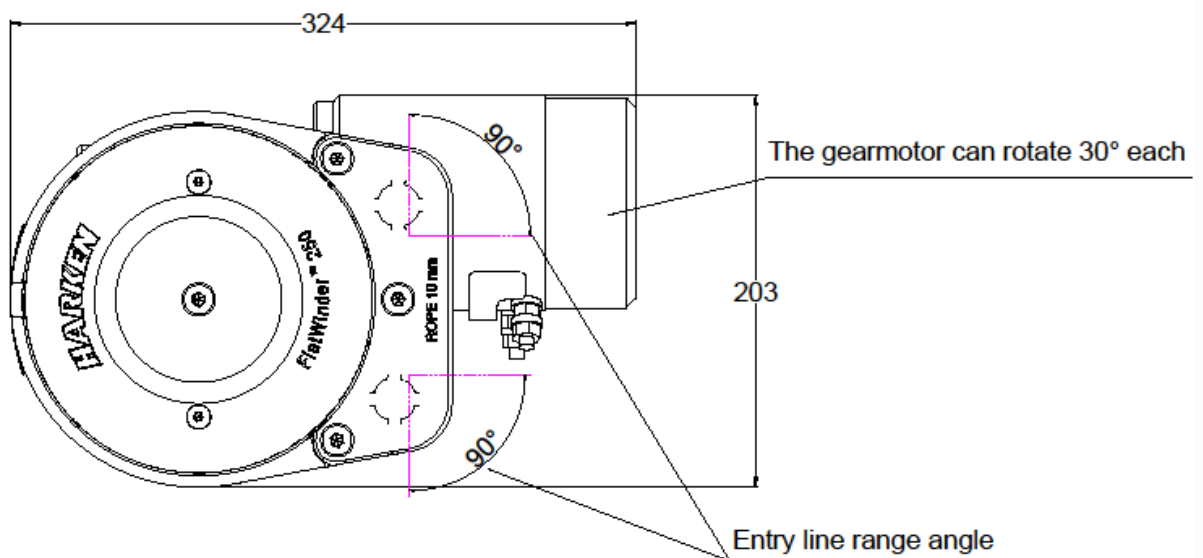
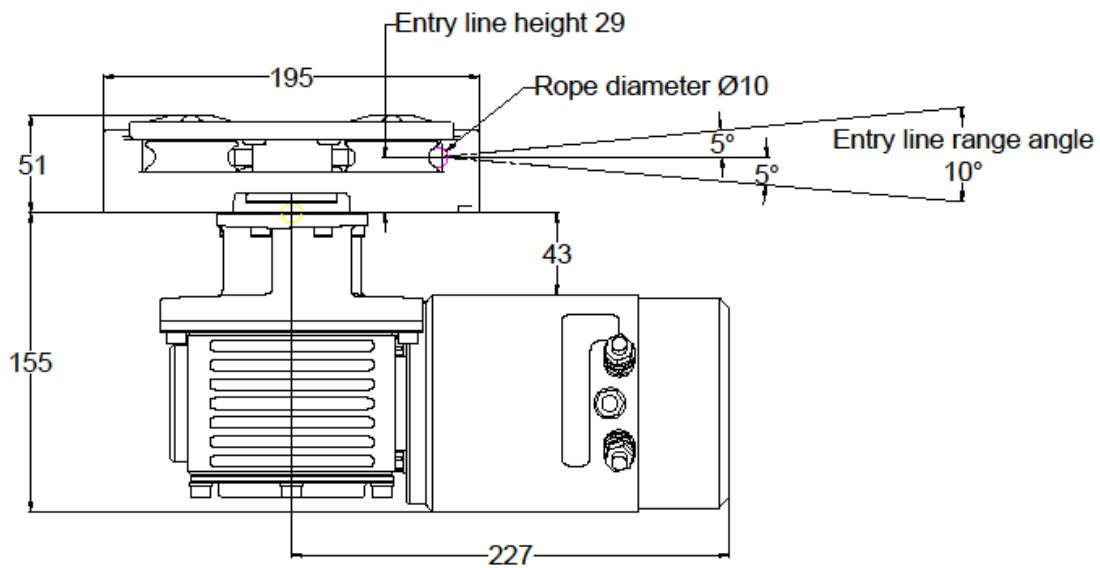

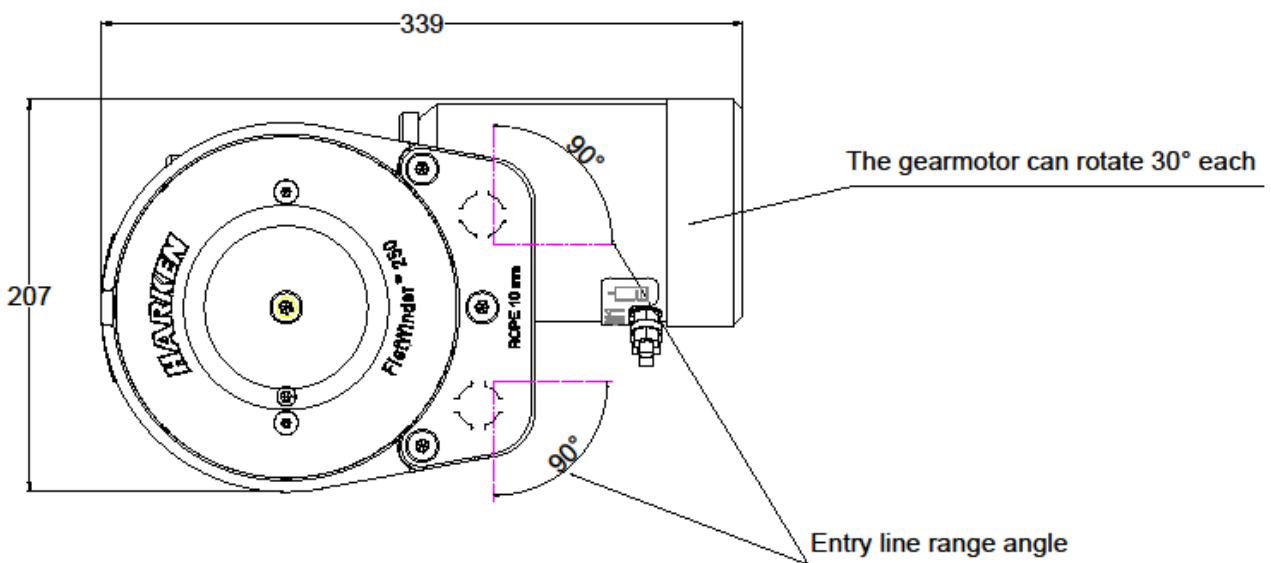
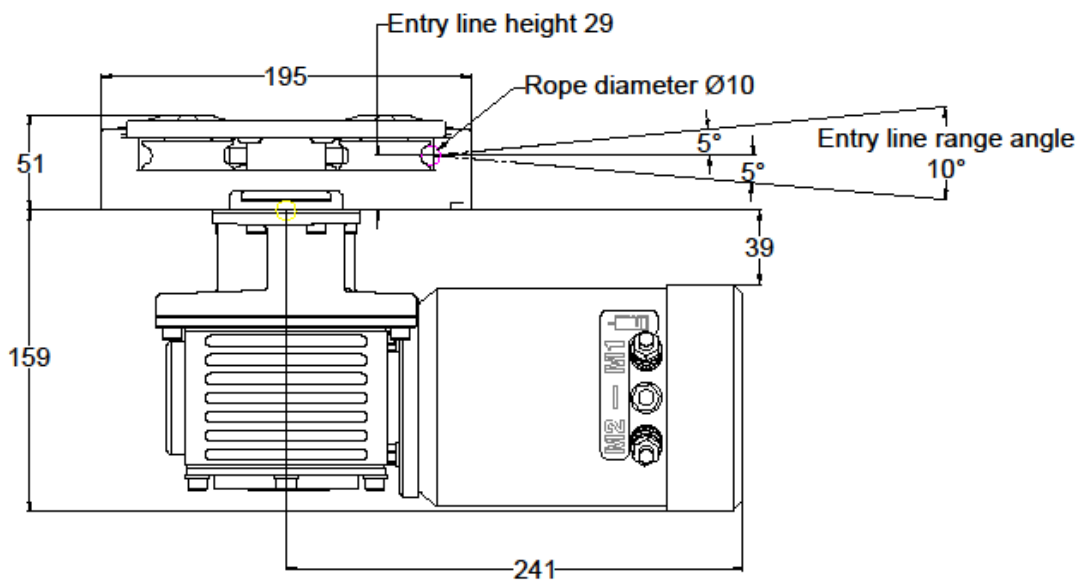
FW250 E 48V

FW250 HY 8cc

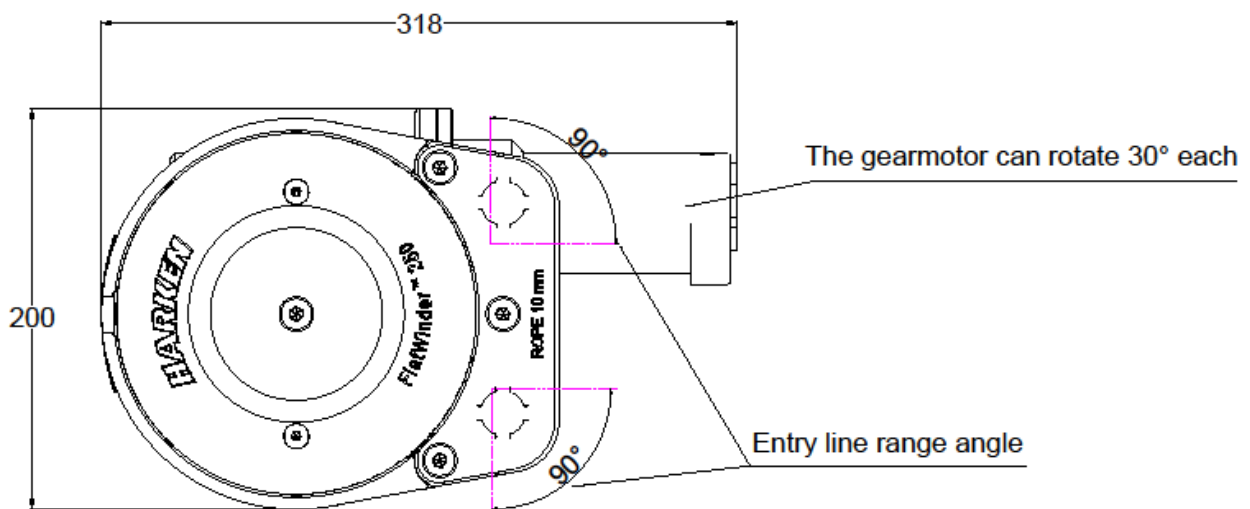
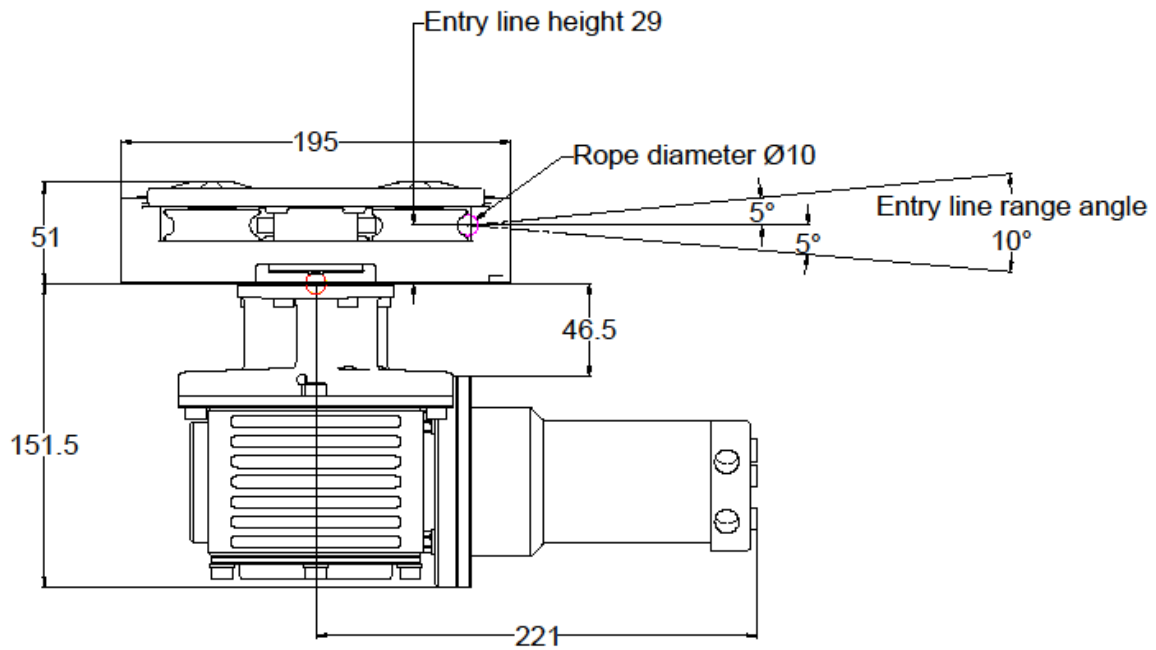

Outline FlatWinder™500

FW500 E 12V/24V

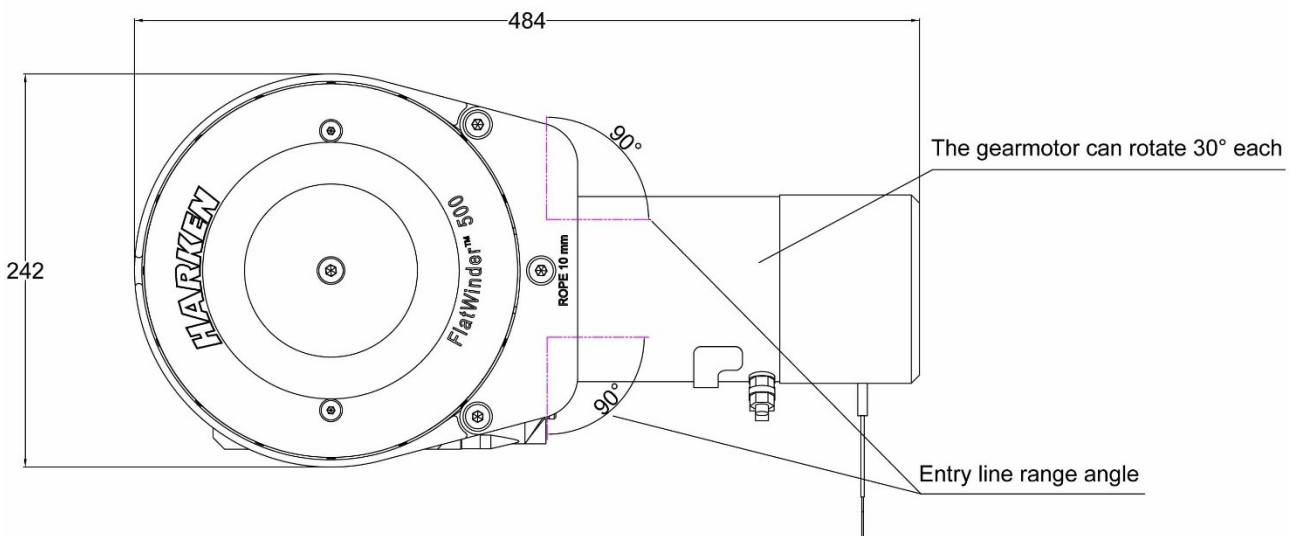
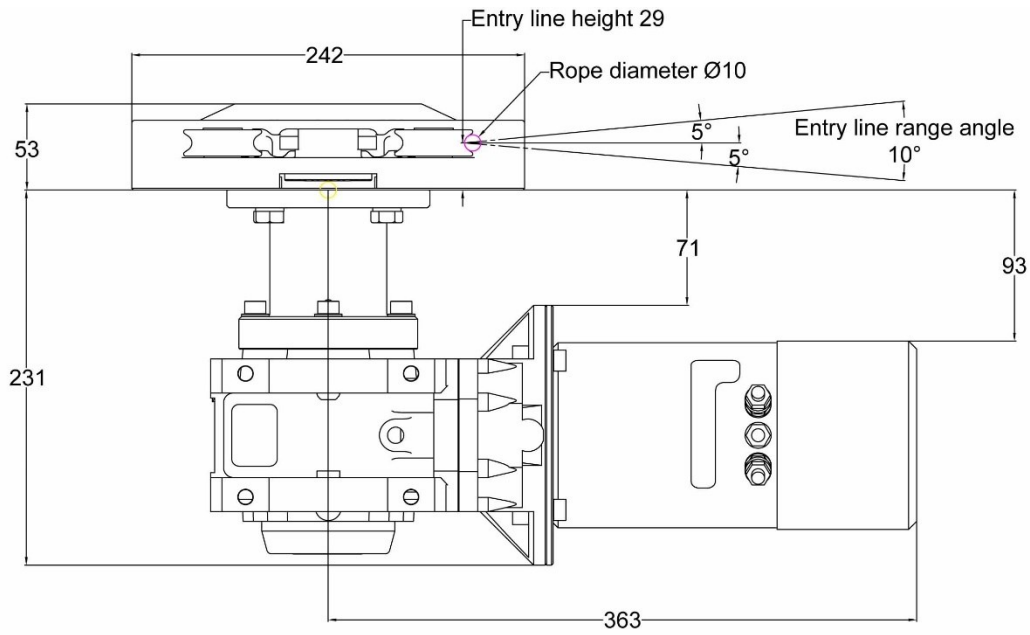

FW500 E 48V

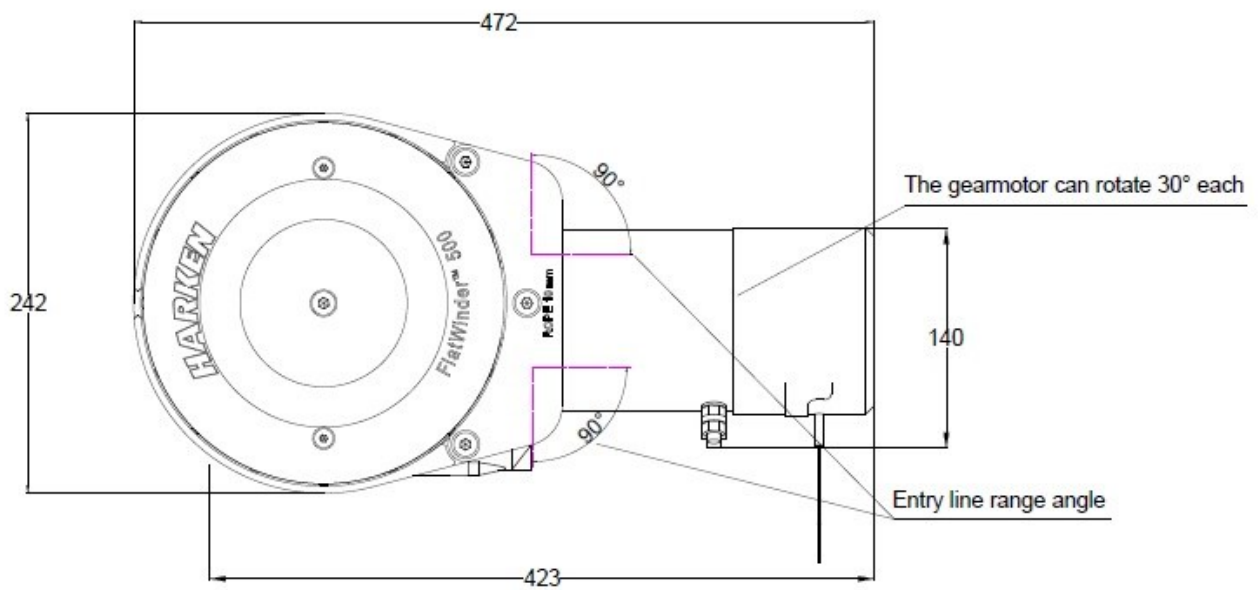
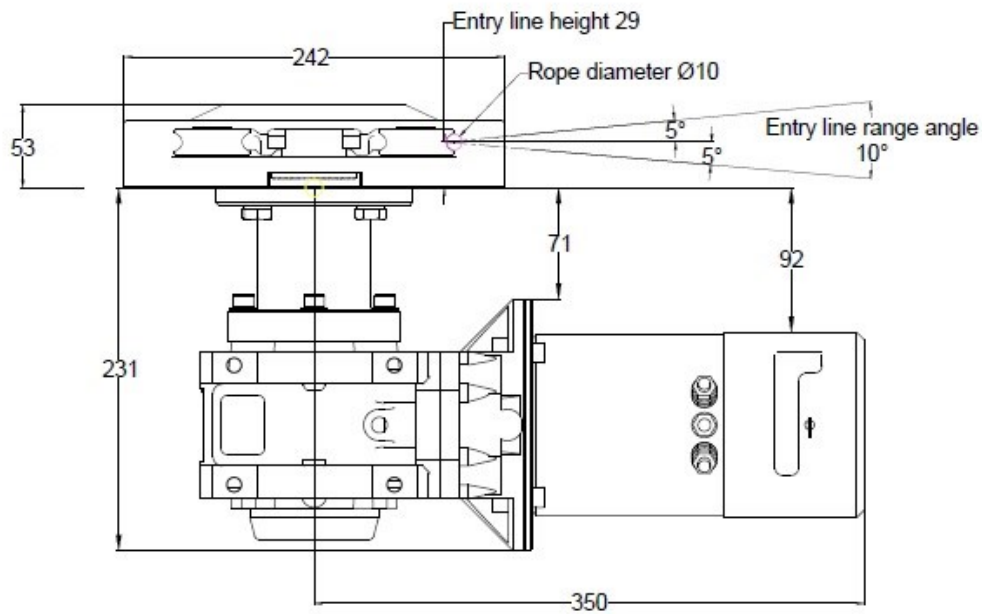

FW500 HY

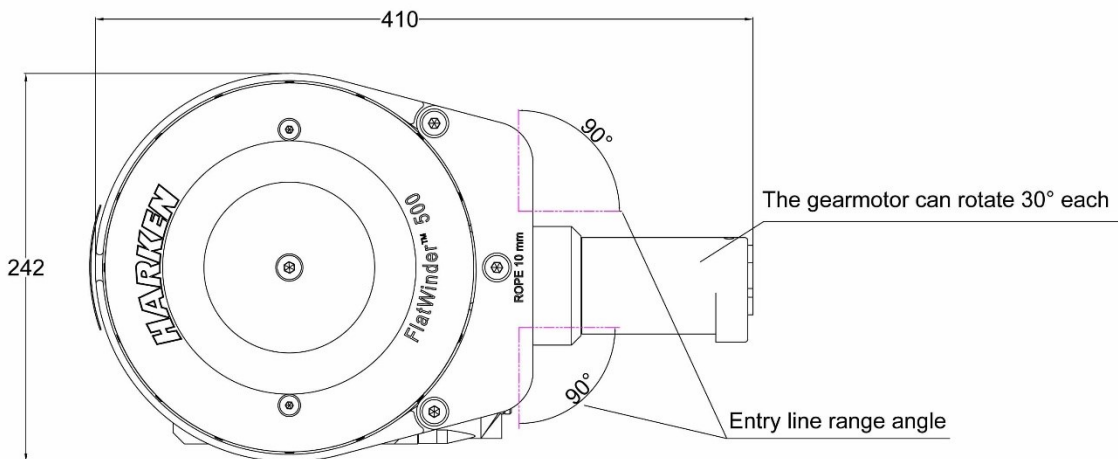
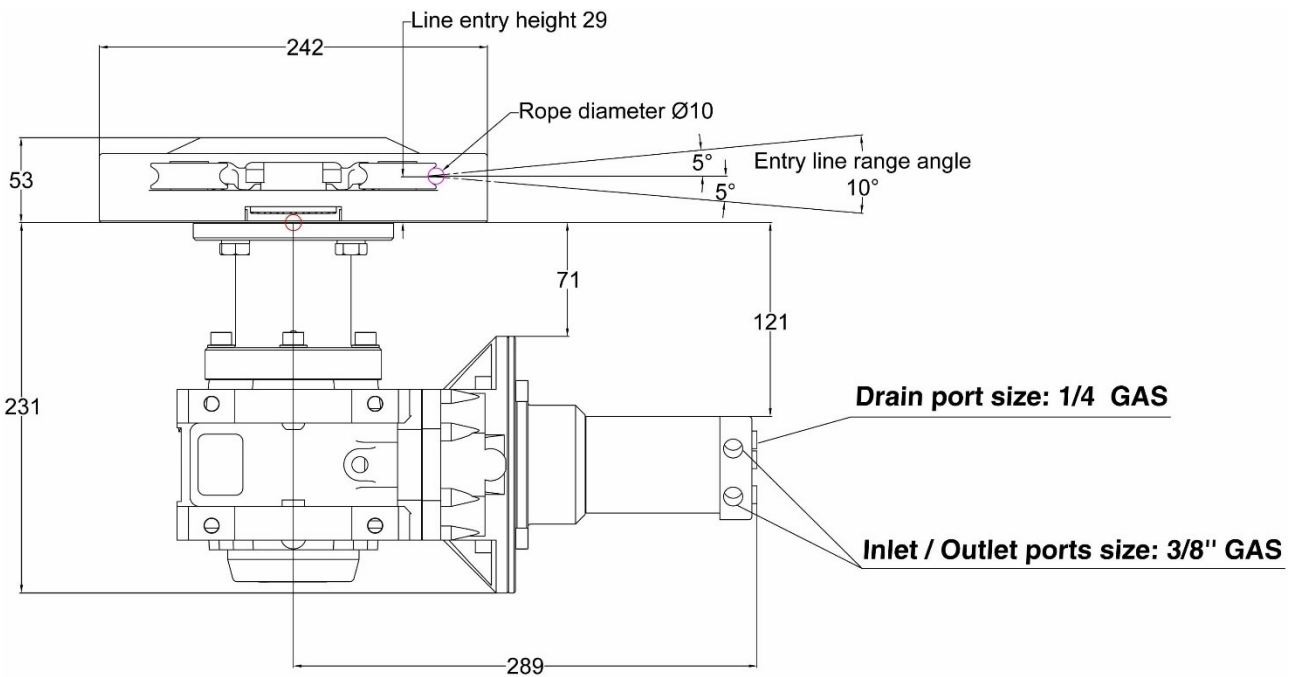

Typical traveler lay-out

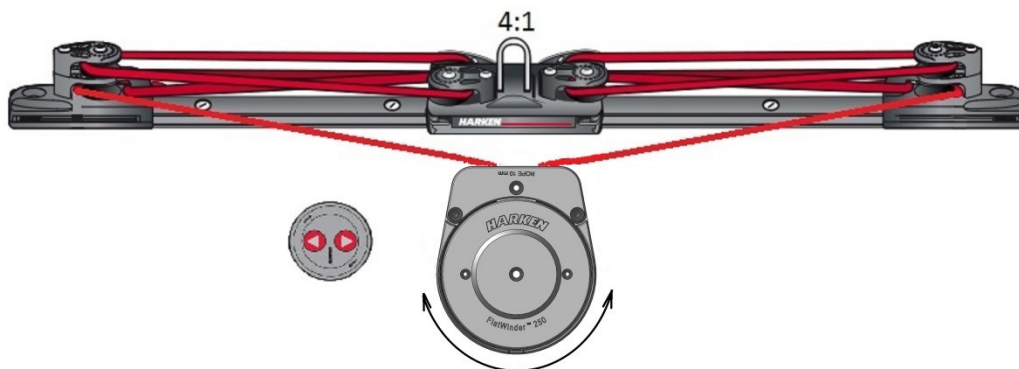

Depending of traveler load can be used 2:1, 3:1 or 4:1 purchase

Installation

The FlatWinder™ must be installed on a flat area of the deck, reinforced if necessary to bear a load equal to at least twice the maximum working load of the FlatWinder™. It is the installer's responsibility to carry out all structural tests needed to ensure that the deck can bear the load.

Harken does not supply the screws needed to install the FlatWinder™ since these may vary depending on the deck on which it is to be installed.

It is the installer's responsibility to choose the correct screws taking account of the loads they will have to bear.

Harken® assumes no responsibility for incorrect installation of its FlatWinder™ or for an incorrect choice of mounting screws.



DANGER!

Incorrect installation of the FlatWinder™ may cause severe injury or death. Consult the yard that built the boat in the case of doubt over the correct positioning of the FlatWinder™.



WARNING!

Failure to use the correct number and type of mounting fasteners or failure to ensure the correct deck strength can result in the FlatWinder™ pulling off the deck suddenly and unexpectedly during high loads causing severe injury or death.



WARNING!

Verify the entry angle of the sheet. This must follow the indication on the outline drawing to avoid overrides or damaging the FlatWinder™.

After correctly positioning the unit, check that the gearmotor, electrical components and wiring can be housed below decks.

To help find the optimal compromise, remember that, to make the installation of the gearmotor easier, it can be coupled to the FlatWinder™ in different positions (rotate each 30°).

Once you have decided the correct mounting position for the FlatWinder™ on the deck and checked the space available below deck, proceed with the installation.

Parts included for FlatWinder™ 250:

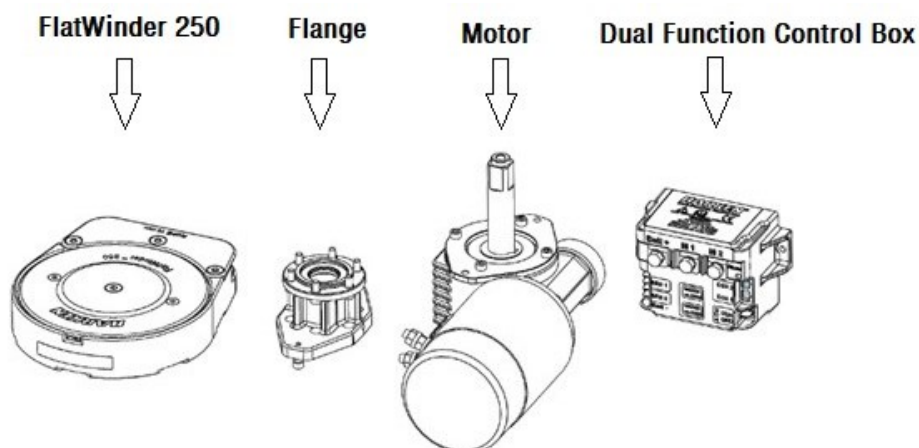

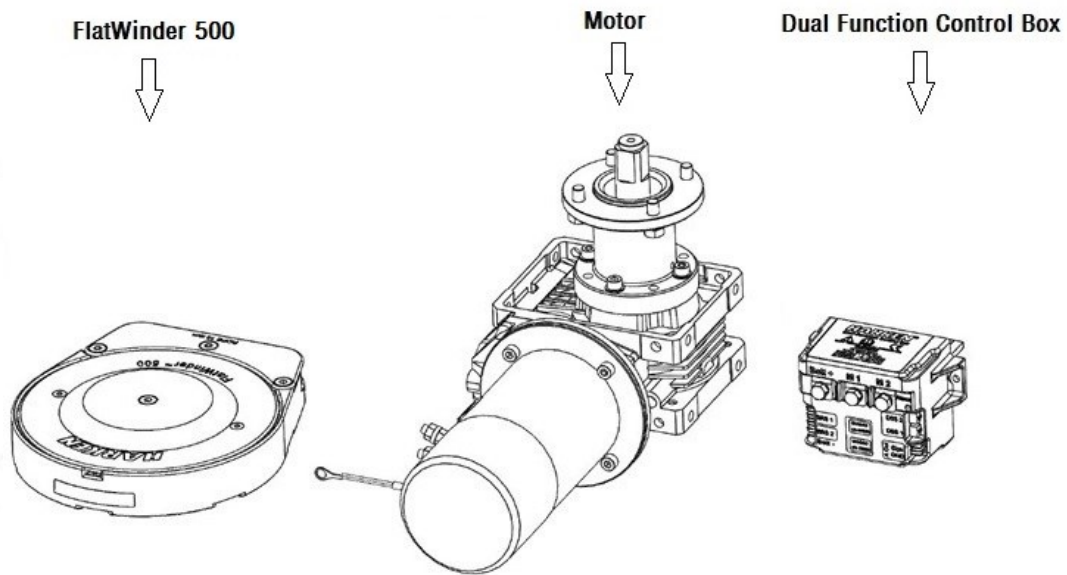
Parts included for FlatWinder™ 500:**FlatWinder™ installation procedure****WARNING!**

Make sure that the power is switched off before installing or carrying out maintenance on the FlatWinder™.

**NOTICE**

Before drilling the deck, check the space available below deck for the flange and the motor

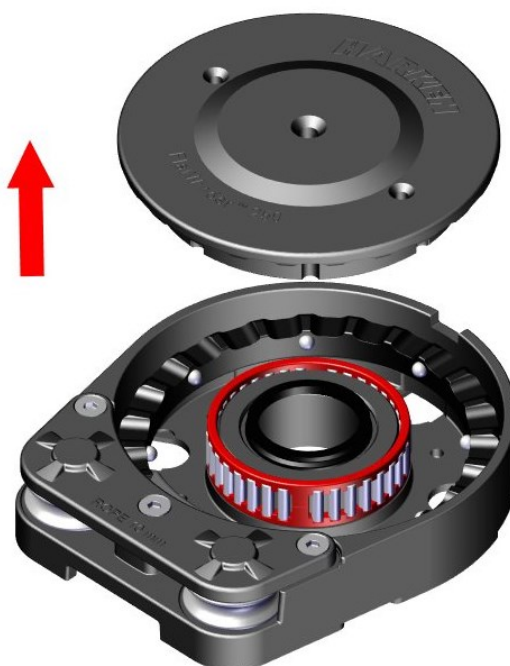
A. Remove the upper jaw (no tool required)

B. Position the base of the FlatWinder™ on the deck and mark the position of the holes or use the drilling cut-out template at the point where you have decided to place the FlatWinder™.

Below is a reduced scale diagram for FlatWinder™ 250.

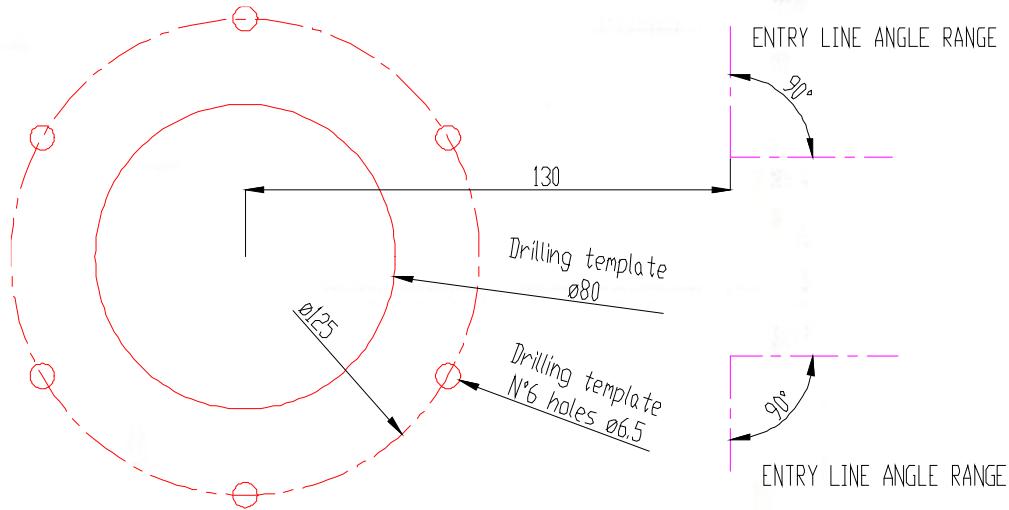

Below is a reduced scale diagram for FlatWinder™ 500.

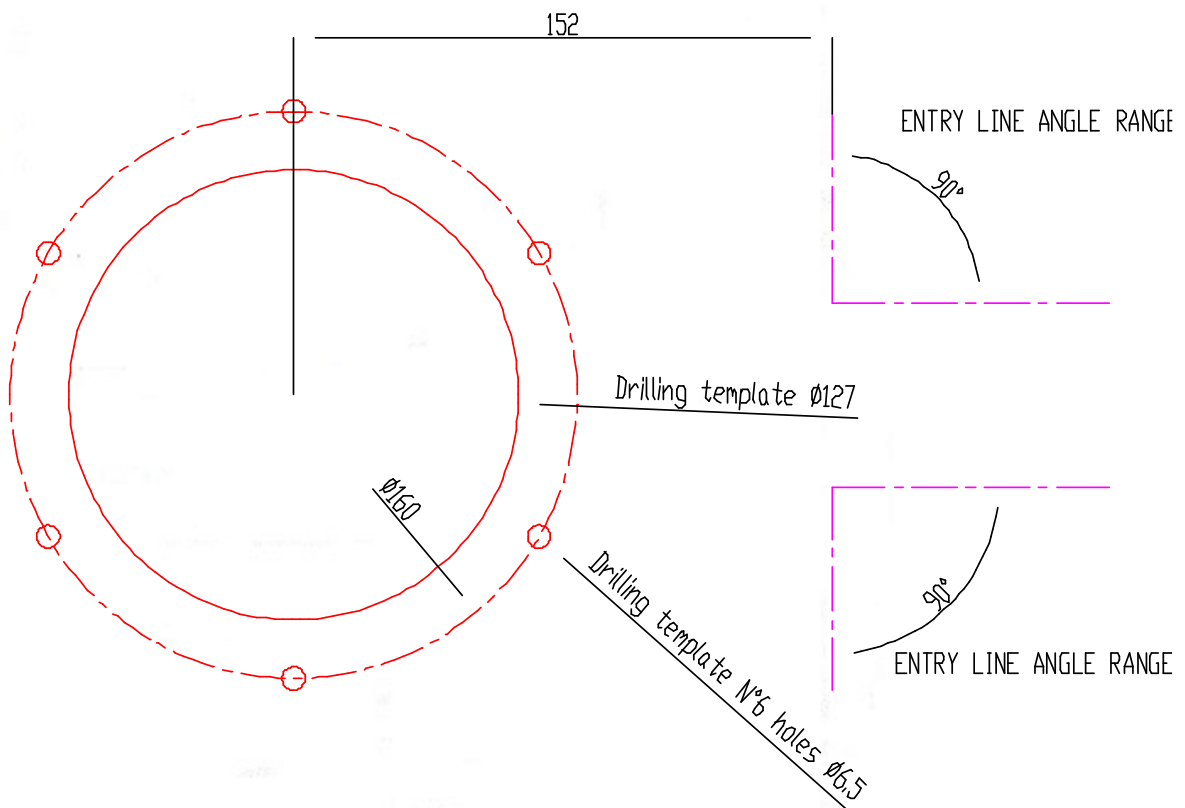

C. Remove the FlatWinder™ base and drill following the drilling template above.

D. Bolt the base of the FlatWinder™ to the deck using six M6 bolts, Socket Head or Hexagonal Headed (not supplied by Harken), correctly chosen for the thickness and type of the boat deck. Consult the yard that built the boat in case of doubt.



WARNING!

To install the FlatWinder™ on the deck, use only bolts in A4 stainless steel (DIN 267 part11). Bolts made of other materials may not have sufficient strength or may corrode which can result in FlatWinder™ pulling off deck suddenly and unexpectedly during high loads causing severe injury or death.



NOTICE

To mount FlatWinder™ on the deck, do not use countersunk bolts.



E. Fill the mounting holes and central hole with a suitable marine sealant.

F. Remove the excess adhesive/sealant from the base drainage channels.

Once you have installed the base of the FlatWinder™ on the deck, proceed with motor installation.

Motor can be coupled to the FlatWinder™ in different positions.

Check the space available below deck and choose the suitable position.

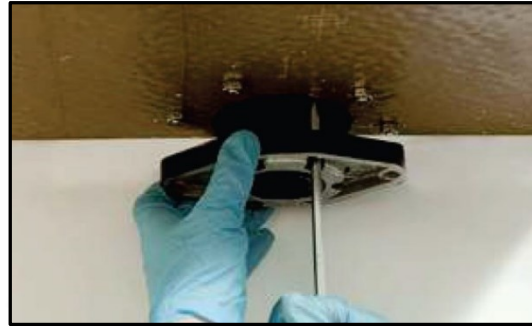
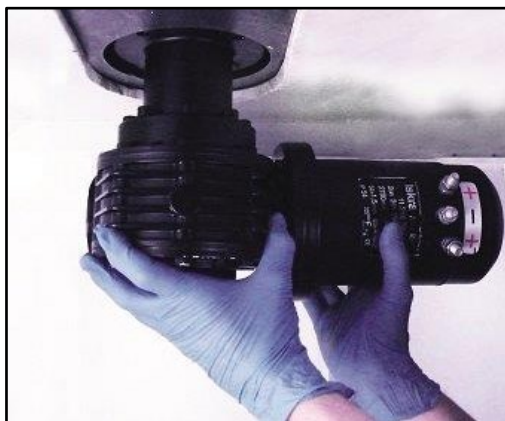
Tools needed for FlatWinder™ 250: A number five hex key Two number thirteen wrenches**G. Position the flange****H. Tighten six M6 precote screws (8Nm/71 in-lb)****I. Position the reduction gear and motor****L. Tighten the two M6 precote screws (8Nm/71 in-lb) - be sure to align the flange****Tools needed for FlatWinder™ 500:** One number seventeen, two number thirteen wrenches**I. Position the reduction gear and motor****L. Tighten the four M10 screws (20Nm/177 in-lb)**

M. Insert the upper jaw, align the white balls on the lower jaw with the grooves on the upper jaw

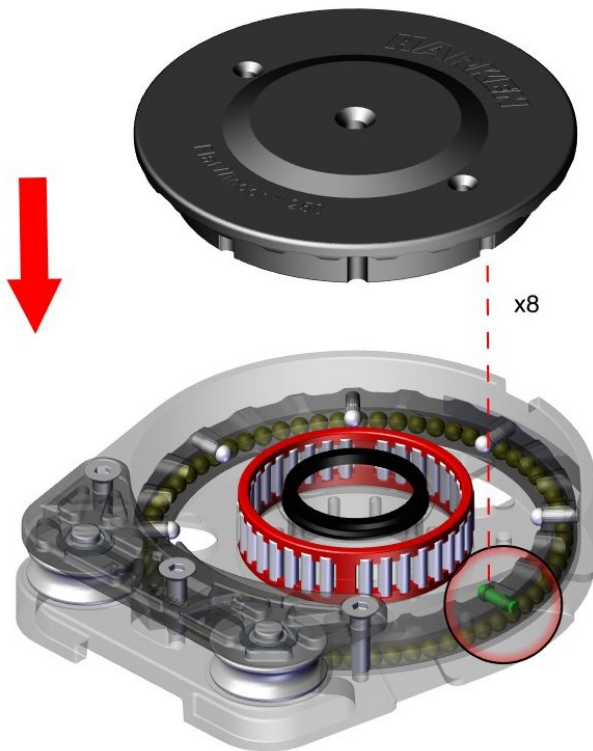

N. Tighten the central M8 screw (20Nm/174 in-lb)

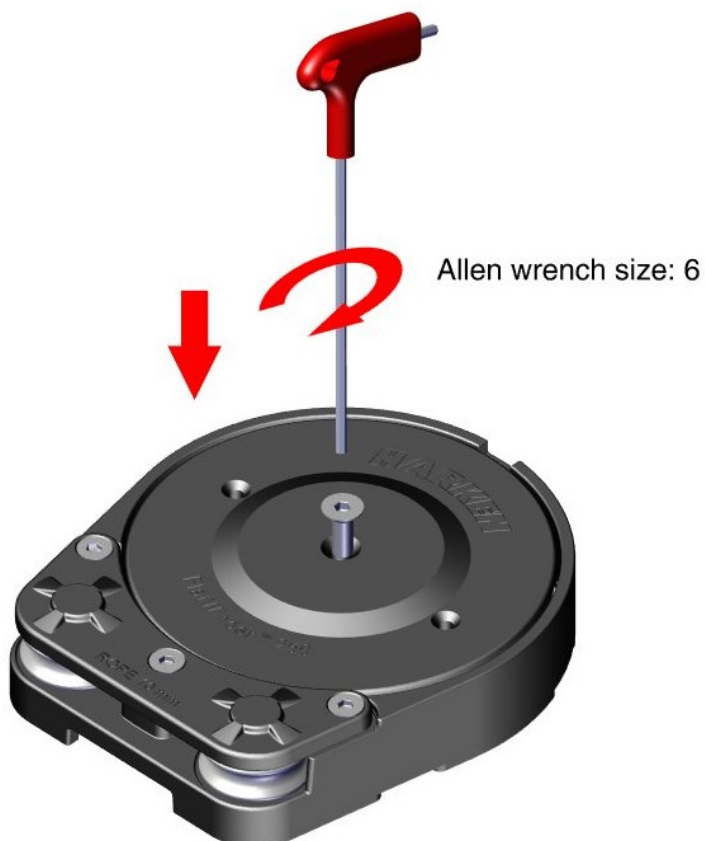

Electric wiring diagrams

To guarantee greater efficiency in terms of safety and long life, for every FlatWinder™ model is mandatory to install the Dual Function Control Box.

For more information, refer to the Dual Function Control Box manual, available on harken website www.harken.com.



WARNING!

Read the Dual Function Control Box manual carefully before installing and using the device.



NOTICE

For other installations, refer to the Dual Function Control Box manual.



NOTICE

In case the direction of movement is not congruent with the DSS arrow invert the M1-M2 cable on the motor or on the Dual Function Control Box.

Fasten the Dual Function Control Box containing solenoids to bulkhead or wall: refer to the Dual Function Control Box manual.

Install remote circuit breaker between power supply and Dual Function Control Box.

Locate push-buttons on deck in a convenient spot for easy FlatWinder™ operation: refer to the Digital System Switch manual.

Refer to the following chart for wire size:

<i>Total distance between FlatWinder™ and battery</i>								
Current voltage	Under 16.4 ft AWG	Under 5 m mm ²	16.4 - 32.8 ft AWG	5 m - 10 m mm ²	32.8 - 49.2 ft AWG	10 m - 15 m mm ²	49.2 - 65.6 ft AGW	15m - 20 m mm ²
12 V	2	32	0	50	00	70	000	95
24V	5	16	3	25	2	35	000	50
48V	10	8	5	16	3	24	000	50

NOTICE

To connect motor, attach cable terminals to clamps between nut and lock nut. Hold nut in contact with motor using a spanner and tighten the other nut with second spanner. Take special care not to turn the central spindles. Be careful not to turn central spindles. These instructions apply when assembling and disassembling. We recommend using a torque wrench so as to obtain a torque equal to and no greater than 10 Nm (88 in-lb).

**NOTICE**

Note that correct electrical contact sequence is: Nut – Cable Terminal – Self-Locking Washer – Lock Nut

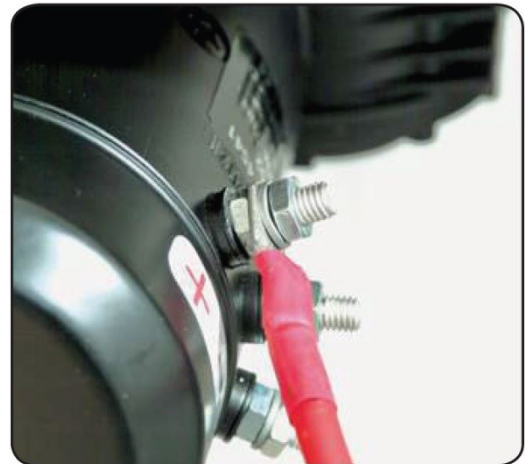

Rope installation

The rope cover should have high wearing resistance. Insert the rope between the pulley and the peeler, turn the FlatWinder™ activating the electric motor on the proper direction.



WARNING!

Do not insert rope bigger than 10mm.
Do not insert rope with splice.



WARNING!

Keep far fingers or clothing when starting the engine to avoid to be entangled into the pulley



WARNING!

In case of close loop line should be check regularly the tension of the rope, depending of temperature and humidity fiber rope can shrink a lot causing over tension on the system

Maintenance

Washing

FlatWinder™ must be washed frequently with fresh water, and in any case after each use.

Do not allow teak cleaning products or other cleaners containing caustic solutions to come into contact with FlatWinder™ and especially anodized, chrome plated or plastic parts.

Do not use solvents, polishes or abrasive pastes on the logos or stickers on the FlatWinder™. Do not use polishes or abrasive pastes on anodized, chromed plated or plastics surfaces.

Make sure that the holes and drainage channels in the base of the FlatWinder™ are not obstructed so that water does not collect.

Maintenance table

FlatWinder™ must be visually inspected at the beginning and end of every season of sailing or racing.

In addition, they must be completely overhauled, cleaned and lubricated at least every 12 months.

After the inspection, replace worn or damaged components. Do not replace or modify any part of the FlatWinder™ with a part that is not original.



WARNING!

Periodic maintenance must be carried out regularly. Lack of adequate maintenance shortens the life of the FlatWinder™, can cause serious injury and invalidate the FlatWinder™ warranty.

Installation and maintenance of FlatWinder™ must be carried out exclusively by specialized personnel.



WARNING!

Make sure that the power is switched off before installing or carrying out maintenance on the FlatWinder™.

In the case of doubt contact Harken Tech Service at techservice@harken.it

Disassembly procedure

Tools needed



A number four hex key
A number five hex key

Remove the central M8 screw



NOTICE

To remove the upper jaw can be used the two top holes M6 as an extractor: in this case, remove the two M6 countersunk screws, insert two M6x70 and tighten up the upper jaw rise.



Harken® limited worldwide warranty

The Harken device is covered by a warranty: if during the warranty period the device proves defective or suffers breakages, as indicated in the warranty, the manufacturer, after checking the device, will repair or replace the defective components.



NOTICE

Modifications carried out by the user, without explicit written authorization from the manufacturer, will invalidate the warranty and relieve the manufacturer of any responsibility for damage caused by the defective product

Refer to the Harken® Limited Worldwide Warranty in the Harken Catalogue and on the website www.harken.com

Ordering spare parts

Spare parts can be requested from Harken as described in the Harken® Limited Worldwide Warranty, indicating the part number in the Parts List and including the serial number of the FlatWinder™ for which the parts are required.

The serial number of the FlatWinder™ is printed inside the base.

L XXXXX
XXXXXXXXXX

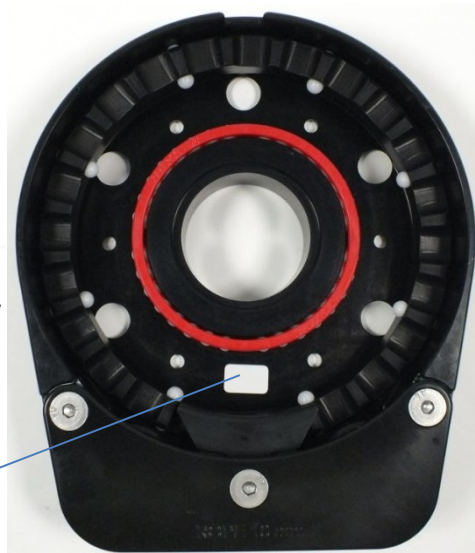

Manufacturer

Harken® Italy S.p.A.
Via Marco Biagi, 14
22070 Limido Comasco (CO) Italy
Tel: (+39) 031.3523511
Fax: (+39) 031.3520031
Email: info@harken.it
Web: www.harken.com

Tech Service

Email: techservice@harken.it

Customer Service

Tel: (+39) 031.3523511
Email: info@harken.it

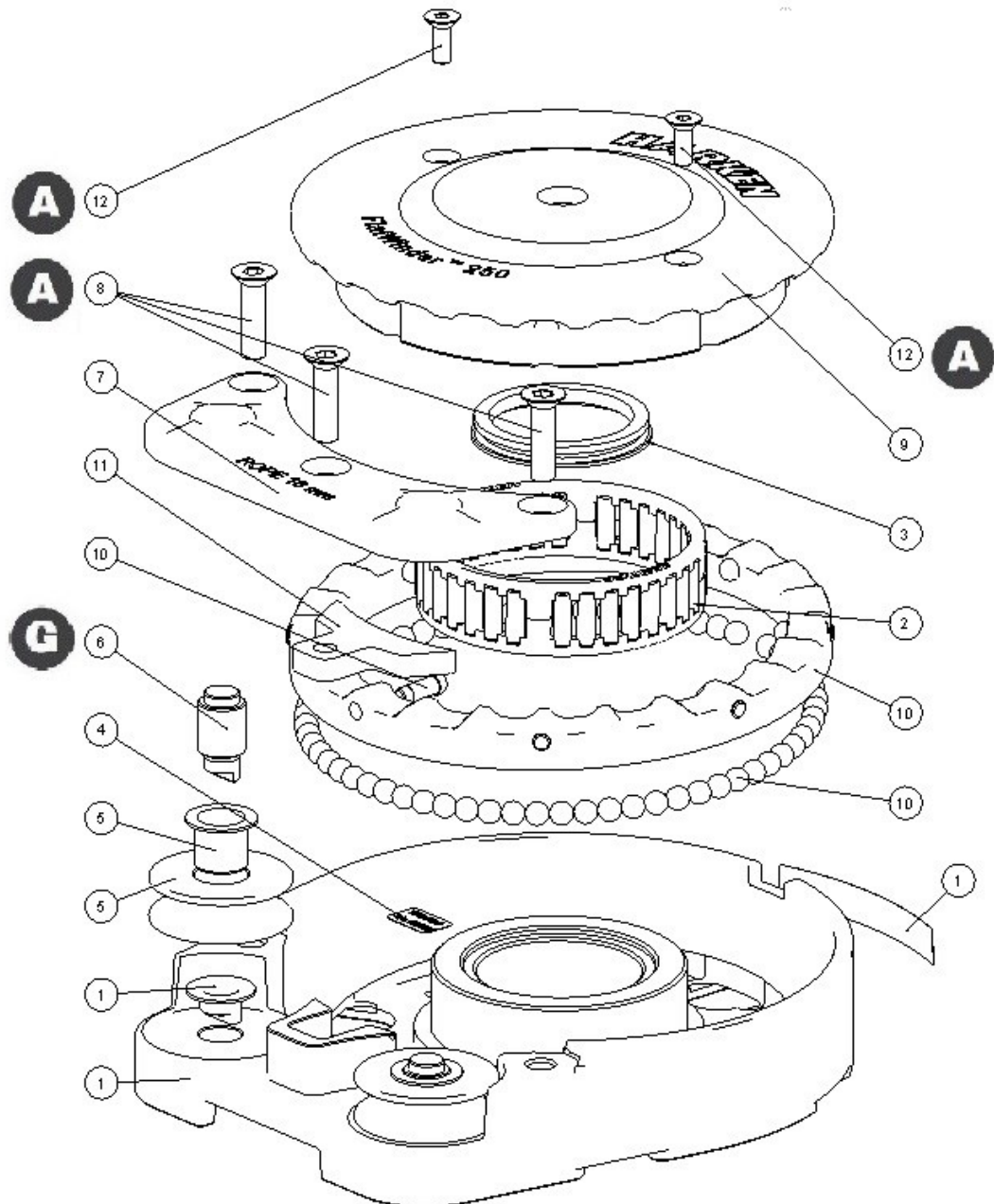
Exploded view*FlatWinder™ 250***A** **Anti-seize****G** **Harken® Grease**

Position	Quantity	Code	Description
1	1	A96901700	Assembly Base
			<i>Base</i>
	2	S413330085	Bushing Ø12xØ14x11
			<i>Device Product Sticker**</i>
2	1	A74135100	Bearing Ø85xØ97x26
3	1	M0651997	Ring Seal
4	1		Device serial number sticker
5	2	A96994000	Assembly pulley Ø48
			<i>Pulley</i>
	1	M0637394	Bushing Ø16xØ18x17
6	2	S699410002	Pin
7	1	S732420082	Plate FlatWinder
8	3	M0632803	Screw M8x30 TSPCE A4
9	1	S690160052	Upper jaw
10	1	A96901500	Assembly lower jaw
			<i>Lower jaw</i>
	66	MP129	Ball 5/16"
	8	S690190080	Spherical pin Ø6x6
11	1	S698380080	Peeler
12	2	M0666603	Screw M6x16 UNI 5933

** Device product sticker



FlatWinder™ 500

- A** Anti-seize
- G** Harken® Grease

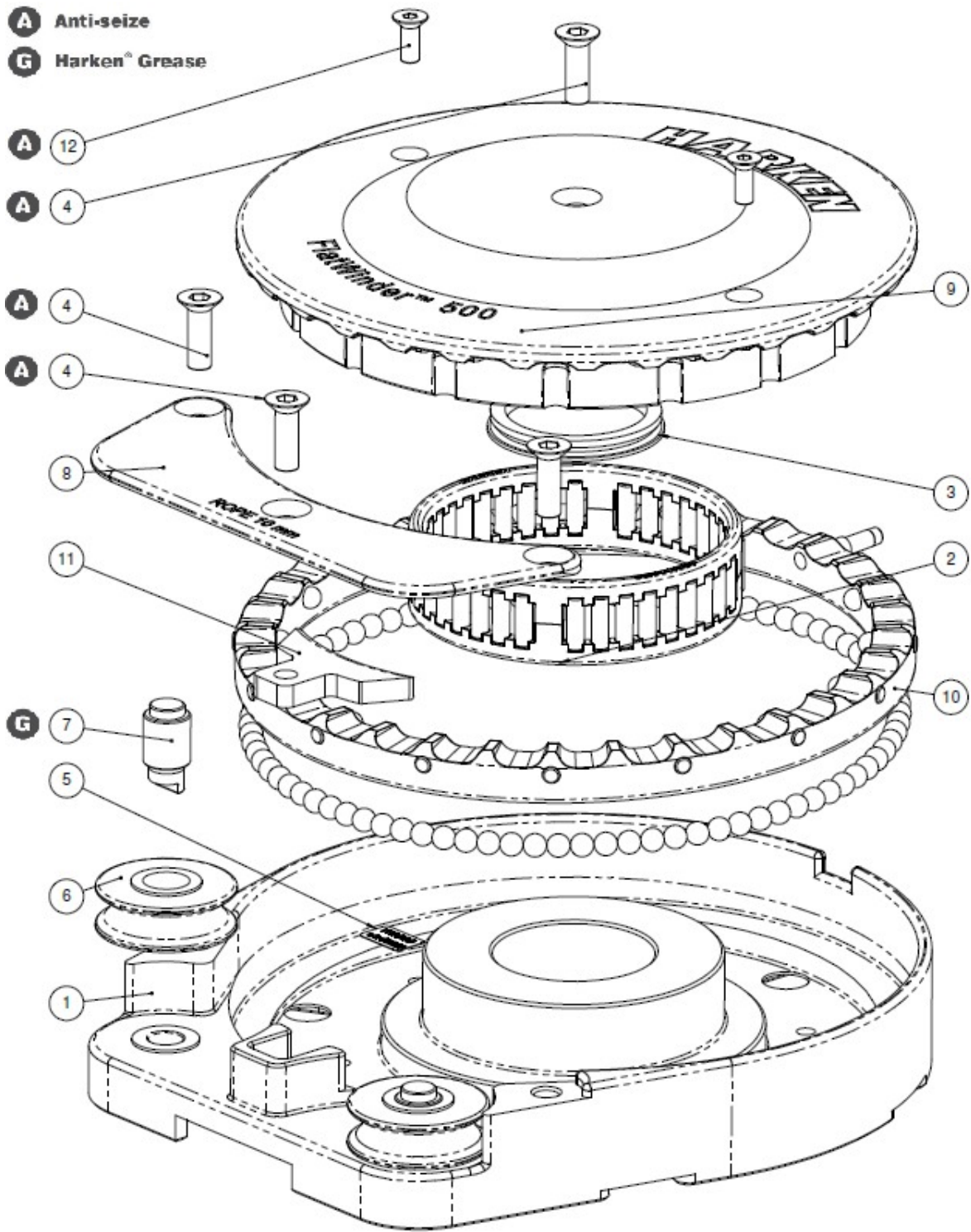

Position	Quantity	Code	Description
1	1	A97042200	Assembly Base
			<i>Base</i>
	2	S413330085	Bushing Ø12xØ14x11
			<i>Device Product Sticker**</i>
2	1	A74147500	Bearing Ø102xØ114x26
3	1	M0651997	Ring Seal
4	4	M0666203	Screw UNI 5933:2003 M8x25-A4
5	1	S418760063	FlatWinder™ Serial Number Sticker
6	2	A96994000	Assembly pulley Ø48
			<i>Pulley</i>
	1	M0637394	Bushing Ø16xØ18x17
7	2	S699410002	Pin
8	1	S704230052	Plate
9	1	S704250052	Upper jaw
10	1	A97042400	Assembly lower jaw
			<i>Lower jaw</i>
	86	MP129	Ball 5/16"
	16	S690190080	Spherical pin Ø6x6
11	1	S698380080	Peeler
12	2	M0666603	Screw M6x16 UNI 5933

** Device product sticker

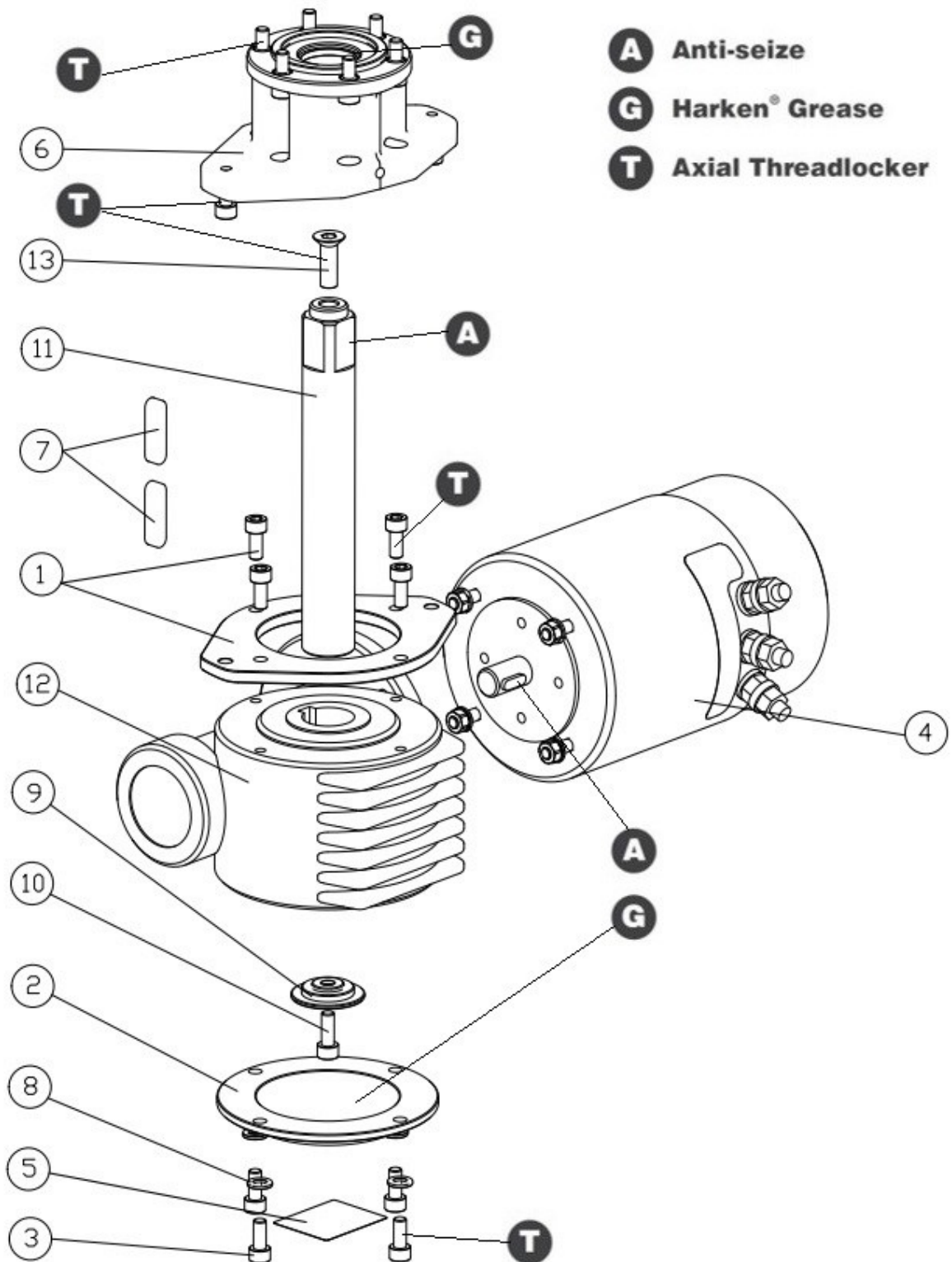

Horizontal electric motor 12V/24V FlatWinder™ 250

Position	Quantity	Code	Description
1	1	A94149200	KIT Assembly Electric Motor Flange
			<i>Electric Motor Flange</i>
	4	M0606803	<i>Screw M6x14 UNI 5931</i>
2	1	S690200080	Flange
3	4	M0606803	Screw M6x14 UNI 5931
4	1	A96015400	KIT EL Motor 12V 0,7kW
	1	A96015700	KIT EL Motor 24V 0,9kW
			<i>Electric motor</i>
			<i>Polarity motor sticker</i>
			<i>Screw stud M6x26</i>
			<i>Washer Ø6</i>
			<i>Nut M6 UNI5588</i>
	1	M6014206	<i>Key DIN 6885 5x5x15</i>
5	1	S477440063	Sticker for gearbox
6	1	A97026100	KIT EL HO Motor Flange FlatWinder
			<i>Horizontal Motorgear Flange</i>
	8	S415360003	<i>Screw M6x16 UNI EN ISO 5931:2003</i>
	8	M6015697	<i>O-Ring Seal Ø5,5xØ1</i>
	1	M0620697	<i>Seal Ø25x Ø47x7</i>
7	2	M0640403	Key 8x7x32
8	4	M0621303	Washer Ø6
9	1	S726070004	Flanged washer Ø6.5xØ35x7
10	1	M0635103	Socket head screw M6x16 UNI 5931
11	1	S690180004	Shaft
12	1	G0675560000	Gearbox worm screw B14 B3 GR60
13	1	M0666203	Screw UNI 5933:2003 - M8x25 - A4

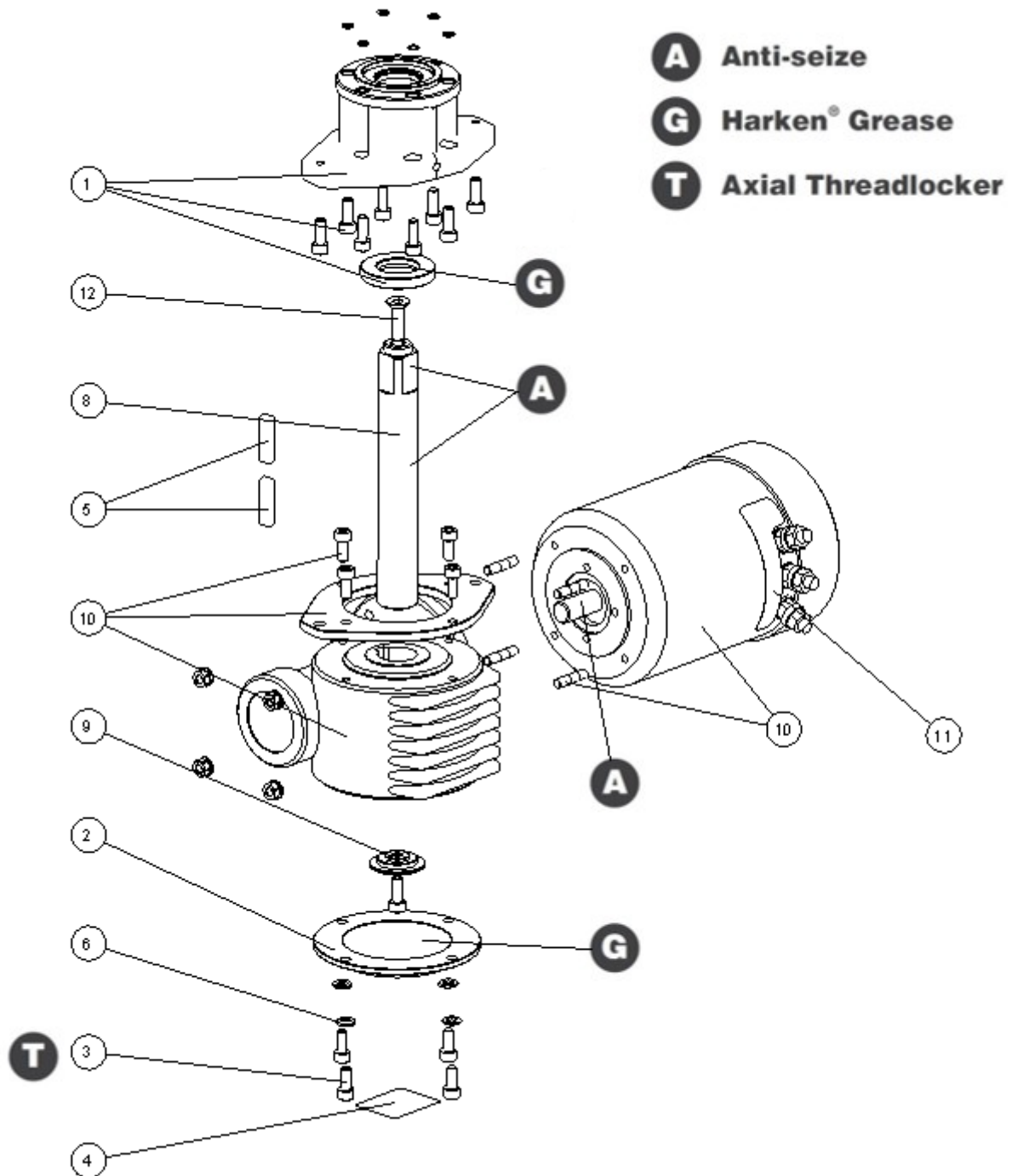
Horizontal electric motor 48V FlatWinder™250

Position	Quantity	Code	Description
1	1	A97026100	KIT EL HO Motor Flange FlatWinder
			<i>Horizontal Motorgear Flange</i>
	8	S415360003	<i>Screw M6x16 UNI EN ISO 5931:2003 precote coating</i>
			<i>O-Ring Seal Ø5,5xØ1</i>
			<i>Seal Ø25xØ47x7</i>
2	1	S690200080	Flange
3	4	M0606803	Screw M6x14 UNI 5931
4	1	S477440063	Sticker for gearbox
5	2	M0640403	Key 8x7x32
6	4	M0621303	Washer Ø6
7	1	M0635103	Socket head screw M6x16 UNI 5931
8	1	S690180004	Shaft
9	1	S726070004	Flanged washer Ø6.5xØ35x7
10	1	A77308700	Assembly gearbox EL HO 48V
			<i>Gearbox worm screw B14 B3 GR60</i>
			<i>Motor 48V 2kW</i>
	4	S312810002	<i>Screw stud M6x26</i>
	4	M0621303	<i>Washer Ø6</i>
	4	M0620803	<i>Nut M6 UNI5588</i>
	1	M6014206	<i>Key DIN 6885 5x5x15</i>
			<i>Flange gearmotor</i>
	4	M0606803	<i>Screw M6x14 UNI 5931</i>
11	1	S480730063	Motor sticker
12	1	M0666203	Screw UNI 5933:2003 - M8x25 - A4

Horizontal hydraulic motor 8cc FlatWinder™250

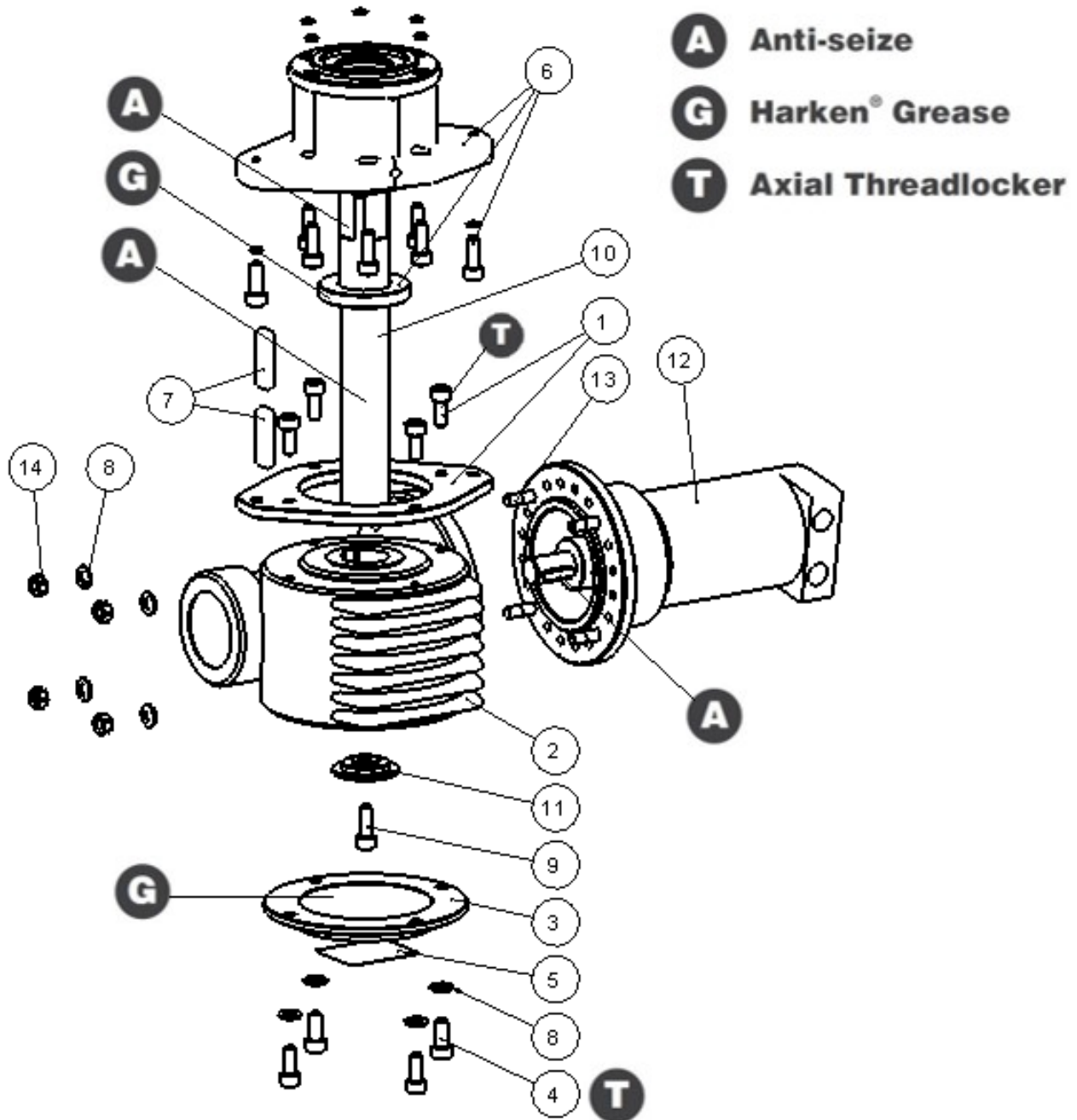

Position	Quantity	Code	Description
1	1	A94149200	Kit motor flange
			<i>Electric Motor Flange</i>
	4	M0606803	<i>Screw M6x14 UNI 5931</i>
2	1	G0675560000	Gearbox worm screw B14 B3 GR60
3	1	S690200080	Flange
4	4	M0606803	Screw M6x14 UNI 5931
5	1	S477440063	Sticker for gearbox
6	1	A97026100	KIT EL HO Motor Flange FlatWinder
			<i>Horizontal Motorgear Flange</i>
	8	S415360003	<i>Screw M6x16 UNI EN ISO 5931:2003 precote coating</i>
	8	M6015697	<i>O-Ring Seal Ø5,5xØ1</i>
	1	M0620697	<i>Seal Ø25xØ47x7</i>
7	2	M0640403	Key 8x7x32
8	8	M0621303	Washer Ø6
9	1	M0635103	Socket head screw M6x16 UNI 5931
10	1	S690180004	Shaft
11	1	S726070004	Flanged washer Ø6.5xØ35x7
12	1	A97207900	Motor assembly HY
			<i>Flange</i>
			<i>Black painted motor</i>
			<i>Hydraulic motor 8CC Ø16 PL3/8 F3VM6</i>
			<i>Screw M6x20 UNI5931</i>
			<i>Shaft</i>
	1	M0647306	<i>Key 5x5x20</i>
13	4	S312810002	Screw stud M6x26
14	4	M0620803	Nut M6 UNI5588

Horizontal electric motor 12V/24V FlatWinder™ 500

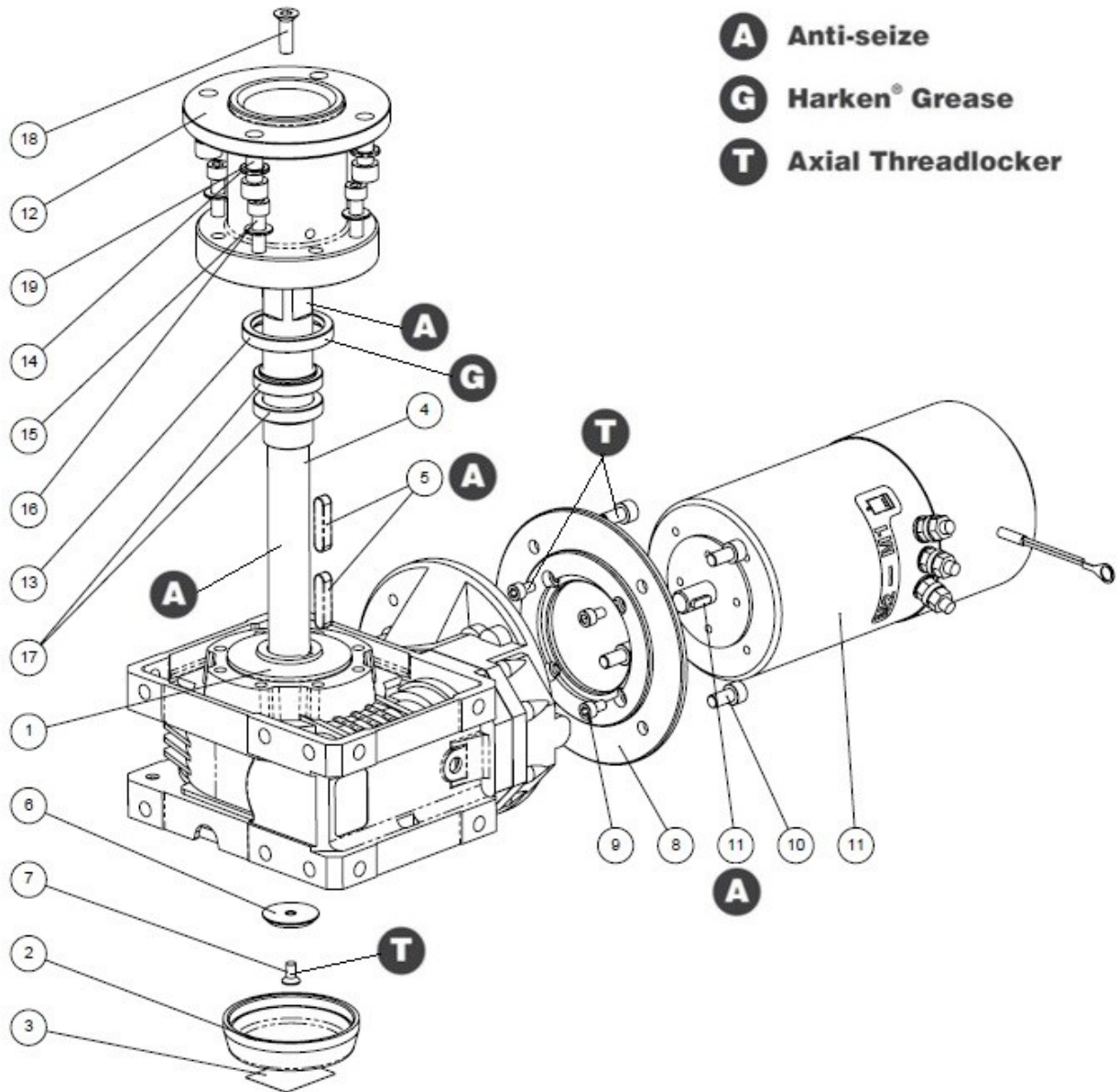

- A** Anti-seize
- G** Harken® Grease
- T** Axial Threadlocker

Position	Quantity	Code	Description
1	1	G606780000	Gearbox orthogonal B5 GR135
2	1	S357050052	Cover for gearbox
3	1	S477440063	Sticker for gearbox
4	1	S704260004	Transmission shaft
5	2	M0628106	Key 8x7x35
6	1	S374870002	Stop Washer
7	1	M0604003	Screw M6x12 UNI 5933
8	1	S705750052	Flange motor adaptation
9	4	M0639103	Screw M6x10 UNI 5931
10	4	M0614403	Screw M8x16 UNI5931
11	1	A97057700	Kit Electric motor 12V 1,5kW with brake
	1	A97057600	Kit Electric motor 24V 2kW with brake
	1		<i>Polarity motor sticker</i>
	1		<i>Motor sticker</i>
	1	M6014206	<i>Key DIN 6885 5x5x15</i>
12	1	S432970052	Flange gearbox B14
13	1	M0673997	Seal 42x55x8
14	4	M0611703	Washer Ø10.5 DIN127
15	4	M0624503	Screw M8x30 UNI5931
16	4	M648703	Washer D.8 ISO 7089
17	2	S432980080	spacer for Seal
18	1	M0666203	Screw UNI 5933:2003 - M8x25 - A4
19	4	M0631003	Screw M10x25 UNI 5931

Horizontal electric motor 48V FlatWinder™500

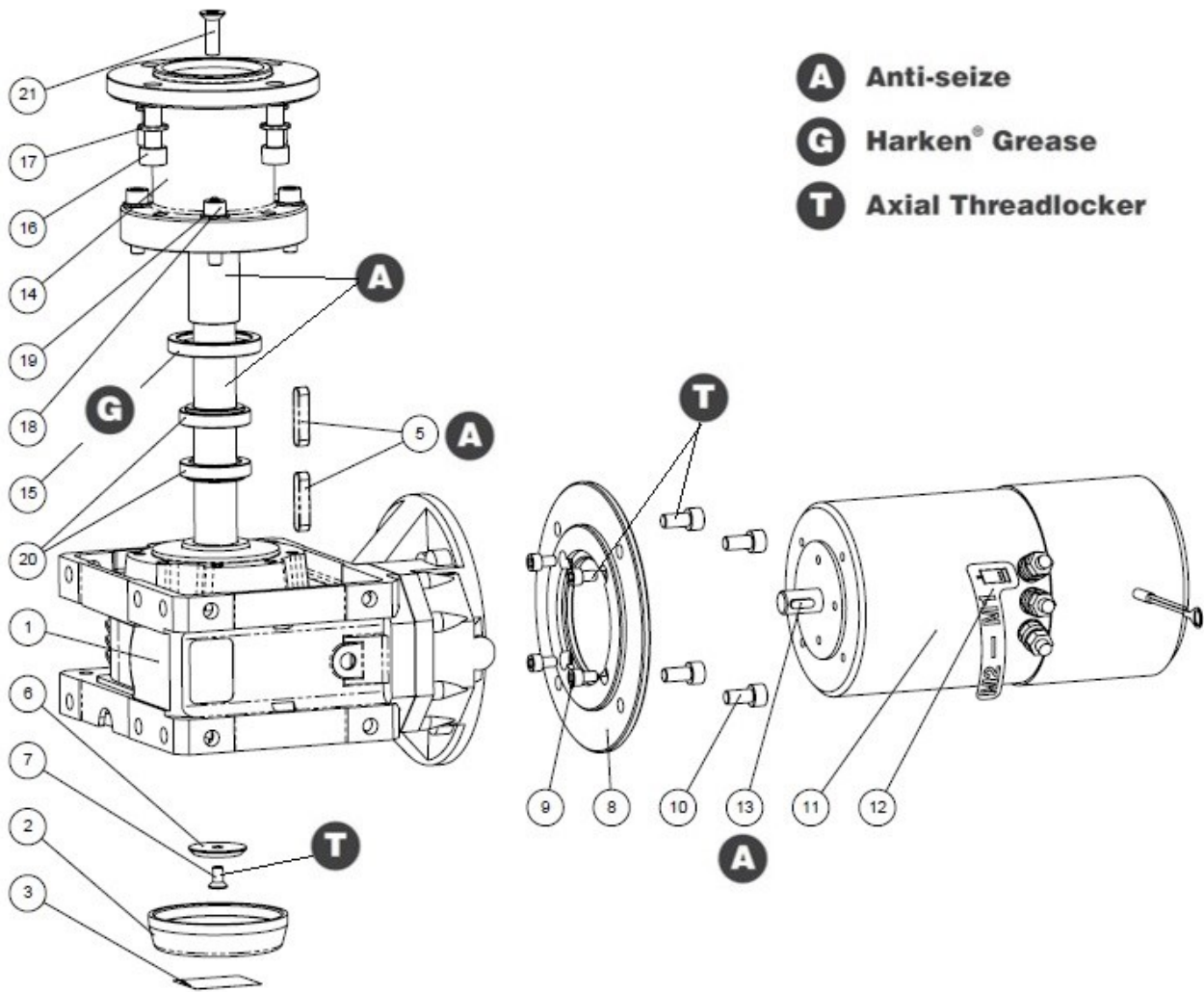

Position	Quantity	Code	Description
1	1	G606780000	Gearbox orthogonal B5 GR135
2	1	S357050052	Cover for gearbox
3	1	S477440063	Sticker for gearbox
4	1	S704260004	Transmission shaft
5	2	M0628106	Key 8x7x35
6	1	S374870002	Stop Washer
7	1	M0604003	Screw M6x12 UNI 5933
8	1	S705750052	Flange motor adaptation
9	4	M0639103	Screw M6x10 UNI 5931
10	4	M0614403	Screw M8x16 UNI 5931
11	1	G60567000E	Motor 48V 2kW with brake and termic
12	1		<i>Polarity motor sticker</i>
	1		<i>Motor sticker</i>
13	1	M6014206	Key DIN 6885 5x5x15
14	1	S432970052	Flange gearbox B14
15	1	M0673997	Seal 42x55x8
16	4	M0631003	Screw M10x25 UNI 5931
17	4	M0611703	Washer Ø10.5 U1751 DIN127
18	4	M0624503	Screw M8x30 UNI5931
19	4	M648703	Washer D.8 ISO 7089
20	2	S432980080	Spacer for Seal
21	1	M0666203	Screw UNI 5933:2003 - M8x25 - A4

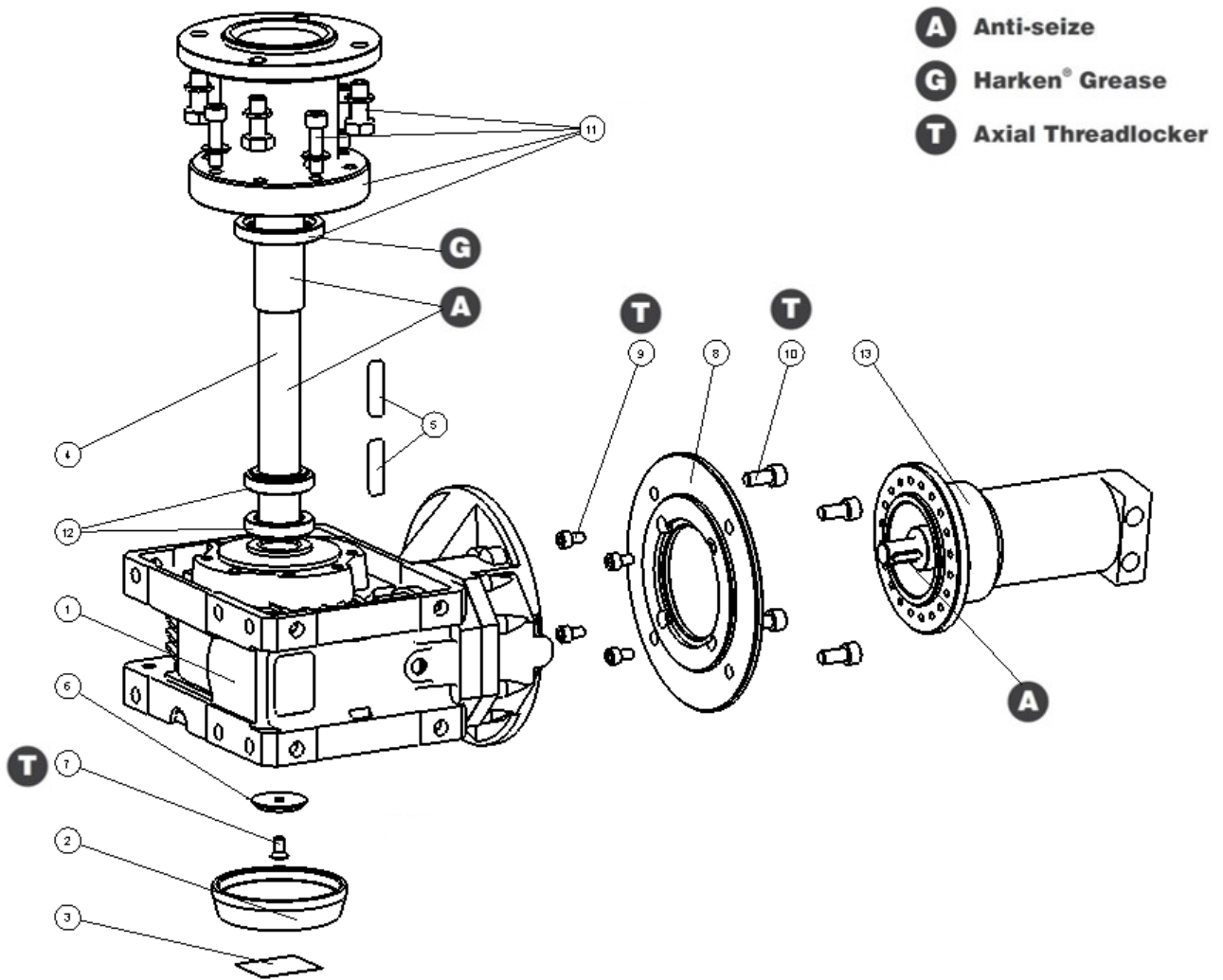
Horizontal hydraulic motor 8cc FlatWinder™ 500

Position	Quantity	Code	Description
1	1	G6067800	Gearbox GR=135
2	1	S357050052	Cover for gearbox
3	1	S477440063	Sticker for gearbox
4	1	S704260004	Transmission shaft
5	2	M0628106	Key 8x7x35
6	1	S374870002	Stop Washer
7	1	M0604003	Screw M6x12 UNI 5933
8	1	S705750052	Flange motor adaptation
9	4	M0639103	Screw M6x10 UNI 5931
10	4	M0614403	Screw M8x16 UNI5931
11	1	A94329700	Assembly flange
			<i>Flange for Gear Box Reduction B14</i>
	1	M0673997	<i>Seal Ø42x Ø55x8</i>
	4	M0623503	<i>Screw UNI EN ISO 4017:2002 - M10x25 - A4</i>
	4	M0611703	<i>Washer Ø10.5 U1751 DIN127</i>
	4	M0624503	<i>Screw M8x30 UNI5931</i>
	4	M648703	<i>Washer D.8 ISO 7089</i>
12	2	S432980080	Spacer for seal
13	1	A97207900	Motor assembly HY
			<i>Flange</i>
			<i>Black painted motor</i>
			<i>Hydraulic motor 8CC Ø16 PL3/8 F3VM6</i>
			<i>Screw M6x20 UNI5931</i>
			<i>Shaft</i>
	1	M0647306	<i>Key 5x5x20</i>

HARKEN®

Contact us

Manufacturer/EU Representative

Harken Italy S.p.A.

Via Marco Biagi 14, 22070 Limido Comasco (CO), Italy

Tel 031.3523511; Fax 031.3520031

Web: www.harken.it

Email: info@harken.it